

Orientation hole
Use wood screw

Rev. date		Project	Webshop	
- 16-01-2024		Description	Emerald Pattern	
		Overschieeseweg 32	Size	A3
		3044 EE ROTTERDAM	Scale	1:15
		The Netherlands	Date	16-01-2024
		Tel.: 010 - 208 37 88	Status	Example
		Fax: 010 - 462 36 51	Client:	Aldowa
		info@aldowa.nl	Project no.	5000249
		www.aldowa.nl	Drawn by	AB
			Edited by	
			Drawing no.	5000249.OVZ0002
			Rev.	-



Panel orientaion

Use a rectangular grid measuring 600 by 653/386 to position panels in the correct alignment.

Maintain a seam or gap of 20mm between panels. For additional measurement information or panel codes, please refer to the IFC file.

Generic screws for standard timber wall applications are included. However, due to variations in characteristics of the back wall as well as unknown variations in the load-bearing capacities, Aldowa is not able or liable for their fitness or suitability to your application. Therefore, for the use of appropriate screws and plugs, please seek professional advice locally or contact Aldowa with more specifics for a non-binding recommendation.

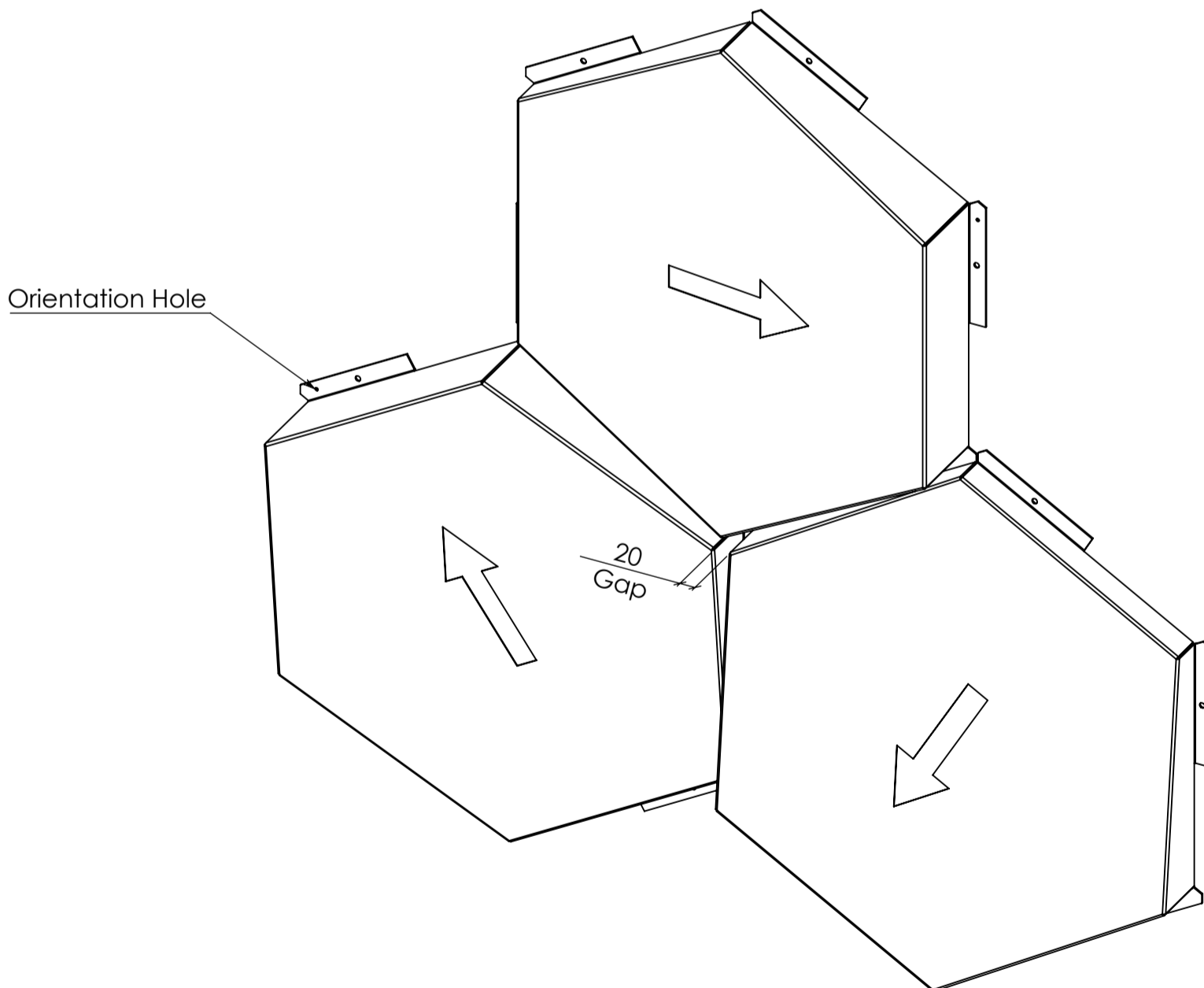
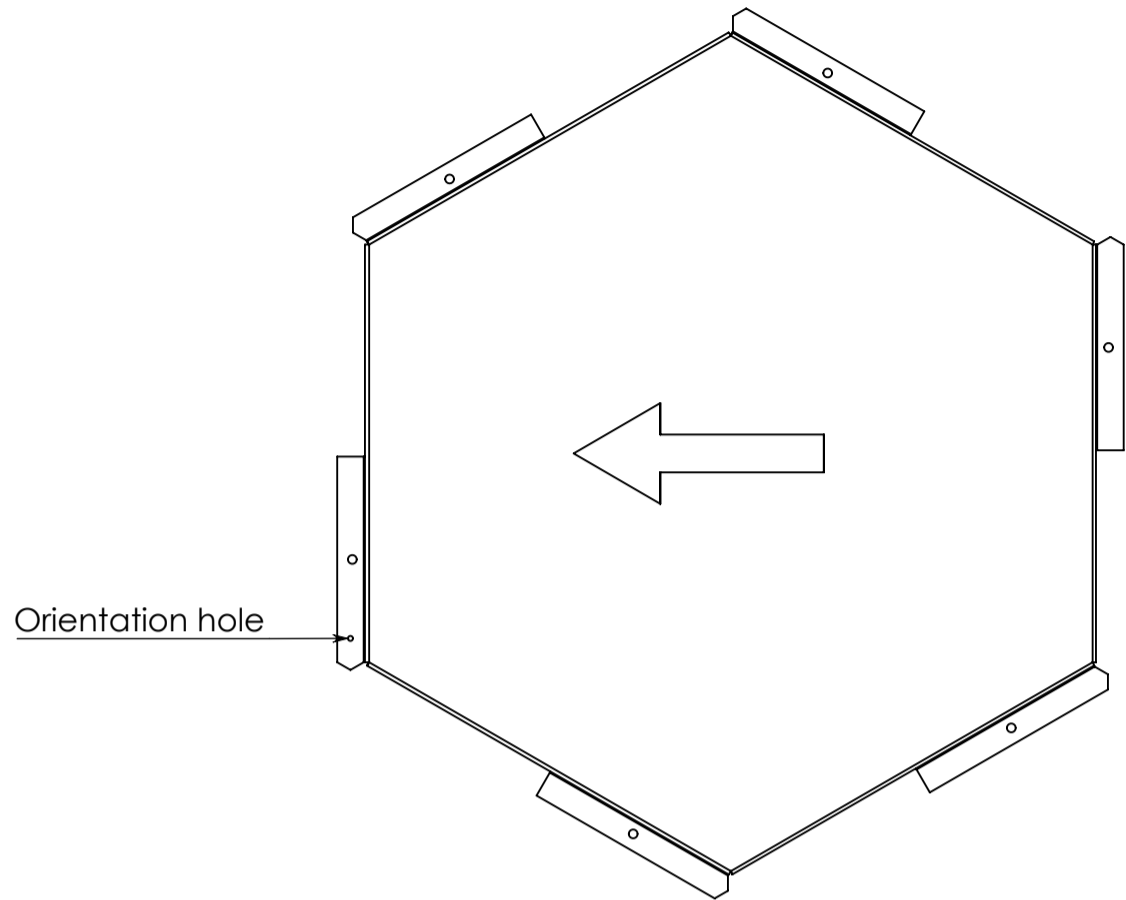

Rev. date		Project	Webshop	
- 16-01-2024		Description	Emerald pattern	
		Overschiezeweg 32	Size	A3
		3044 EE ROTTERDAM	Scale	1:15
		The Netherlands	Date	16-01-2024
		Tel.: 010 - 208 37 88	Status	Example
		Fax: 010 - 462 36 51	Client:	Aldowa
		info@aldowa.nl	Project no.	5000249
		www.aldowa.nl	Drawn by	AB
			Edited by	
			Drawing no.	5000249.OVZ0002
			Rev.	-

